

ERDWICH
SINGLE-SHAFT-SHREDDER

M700/1-600
M700/1-900

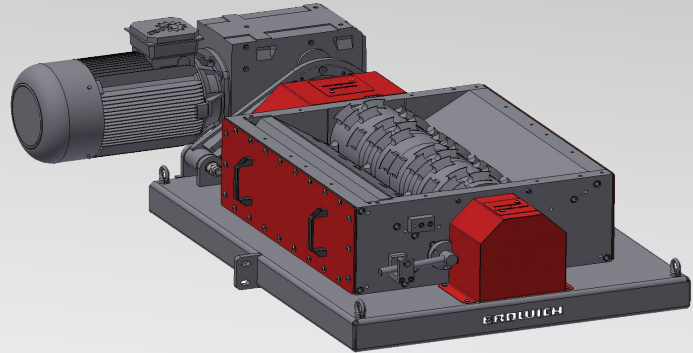

Advantages and special features:

ERDWICH M700/1

■ **Simple maintenance:**

| Individually fitted, replaceable cutter discs on the cutter rotor

■ **Savings on operating costs:**

| Long service life guaranteed by cutters fully hardened to permit repeated re-sharpening

■ **Configurable throughput and particle size:**

| Configurable population of the cutter discs on the cutter rotor and individual perforated screen geometries

| Optimal feed-in thanks to use of a special pressure angle for the cutters and optimum shredding results even at low speeds

■ **Moist material processing possible:**

| With externally placed shaft bearings and integrated bulkhead seals, no milled product or liquid materials can enter the bearings.

■ **Low-noise, low-dust operation:**

| Slow-running rotor

■ **Tailor-made plant, even where space is at a premium:**

| Custom cutter element models and a range of drive system options

■ **Efficient, safe operation:**

| PLC unit featuring automated reverse and power down to protect the machine against damage from overloading or solid parts

ERDWICH
SINGLE-SHAFT-SHREDDER

M700/1-600
M700/1-900

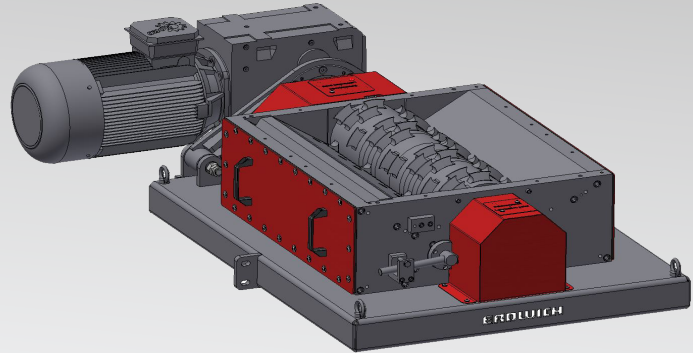

Technical Data:

Typ	Amount of stator knives	Drive power	Cutting unit size (LxW mm)	Gewicht in kg	Diameter of punched sieve (mm)	Width of rotor knife* (mm)
M700/1-600	1	7,5 - 30 kW	580x 670	1610	10 - 50	30
M700/1-900	1	7,5 - 30 kW	880 x 670	1850	10 - 50	30

Dimensions:			
	Dimension	M700/1-600	M700/1-900
Cutting unit length B	mm	580	880
Cutting unit width F	mm	670	670
Cutting unit height A	mm	320	320
Total length C	mm	1.544	1.844
Total width D	mm	1.350	1.350
Total height E	mm	462	462

Subject to technical changes.

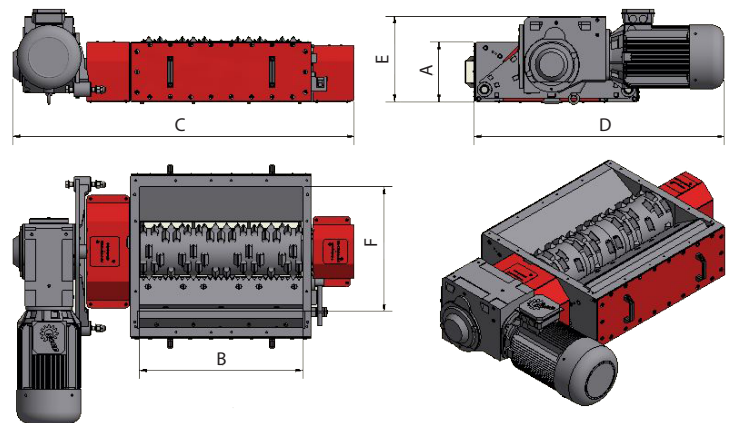

Maße C, D und E variabel, je nach Antriebskonzept